

Small Gas Turbine Engine Handbook



By Ian F Bennett

Small Gas Turbine Engines

Introduction

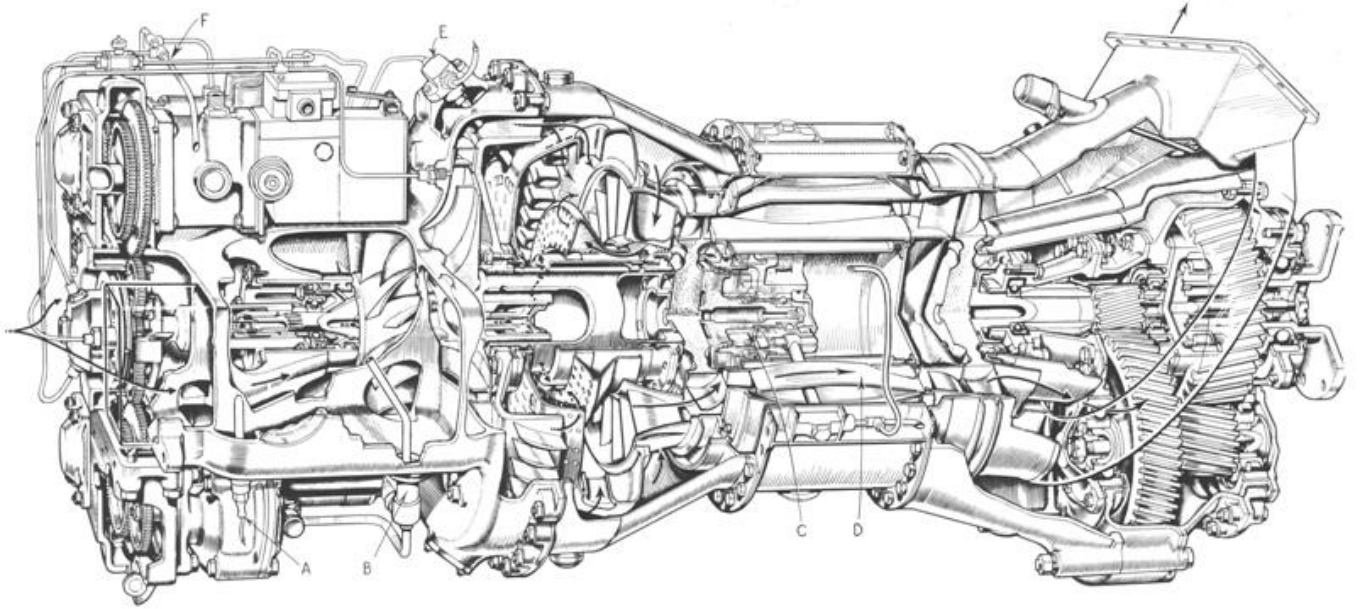

Since an early age I have been interested in electronics, radio and many mechanical devices of all sorts. The electronics interest has resulted in a hobby and a career and more recently a number of events inspired my interest in the last great prime-mover of the 20th century.....the gas turbine.

In 1986 a colleague at work gave me an old scrap diesel engine turbo-charger, this unit I dismantled to discover its internal workings and investigate a complete seizure of the rotating parts. I expect that the unit was scrapped due to this fault! Having taken the unit apart it reminded me of lessons taken at school which explained in simple terms how a jet engine worked. Looking at the turbo I couldn't help wondering if it could be made to work as a simple gas turbine, it wasn't until 1993 that I proved this theory possible. Further gas turbine inspiration came in the form of a couple of foreign holidays traveling aboard the ubiquitous Boeing 737. Upon my return I was browsing a technical book shop in London; I came across a fascinating publication called "Aircraft Gas Turbine Engine Technology" written by Erwin Treager. I had looked at aero-engine books before but had never found one as practical and as comprehensive as this one. Gas turbine books or gas turbine sections in books either seem to consist off children's drawings or pages of mathematics with hardly any practical diagrams or illustrations. The Treager title contained a richly illustrated wealth of information, diagrams, photos and examples; it was like a car workshop manual but for aircraft engines. I purchased this book, it wasn't cheap at £40 (Circa 1988), but well worth it, I haven't come across a better title since. This book my "Bible" was the primary sources of inspiration to build, collect and operate small gas turbine engines.

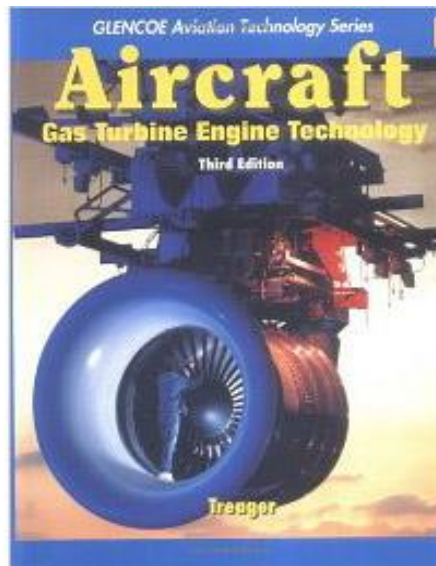

Aircraft Gas Turbine Engine Technology written by Erwin Treager

The Treager book contained many illustrations; one showed the original experimental turbo-jet built by Frank Whittle "The Whittle Unit". The "WU" consisted of a huge single combustion chamber joining a supercharger compressor to a turbine, this arrangement looked as if it could be reproduced with my diesel turbo and some sort of add-on combustion chamber.

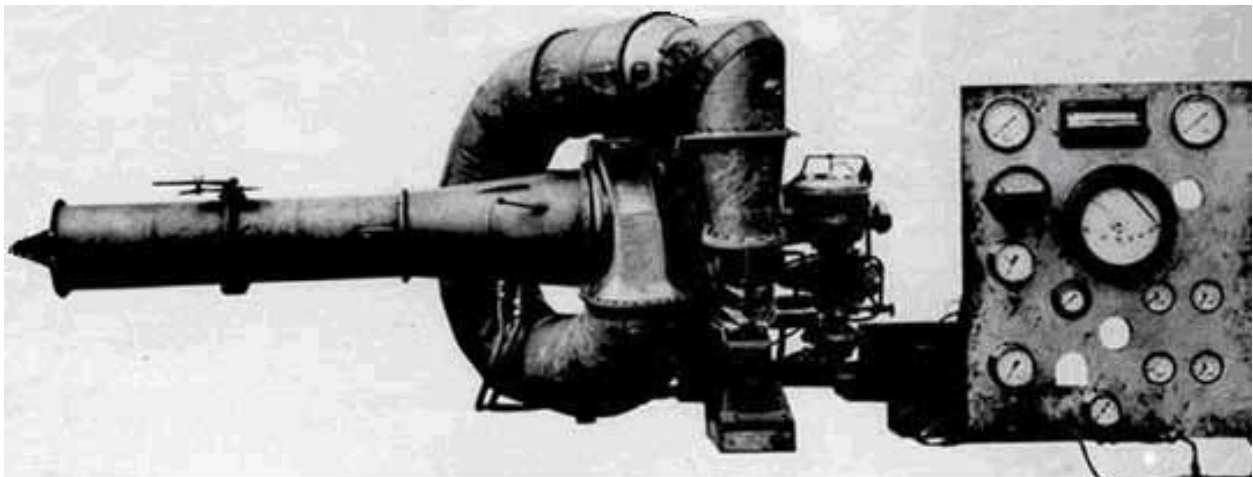

Prototype gas turbine turbojet engine built by Frank Whittle

[Small Gas Turbines by Ian F Bennett](#)

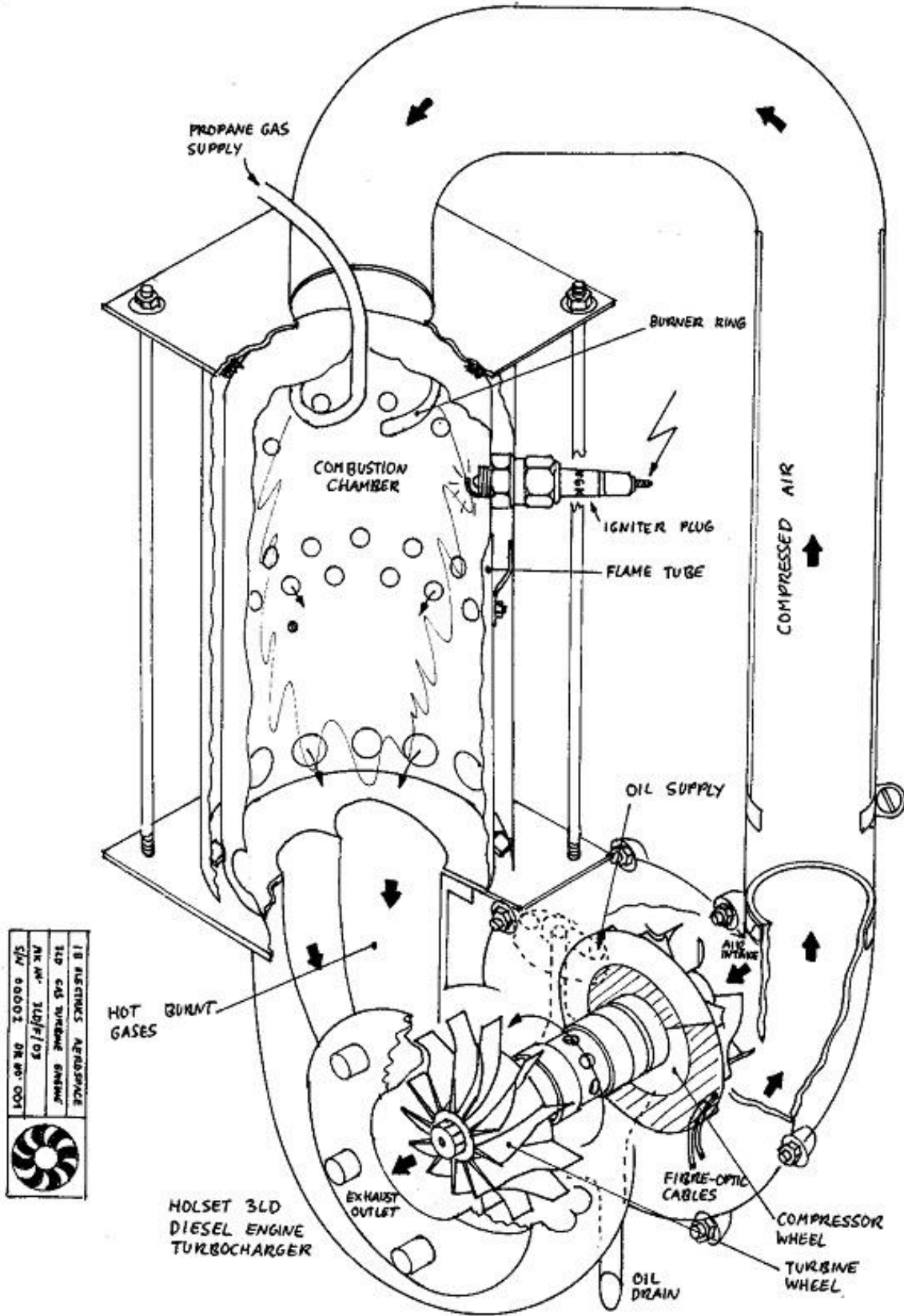

The authors' "artist's impression" turbocharger-based gas turbine circa 1993

[Small Gas Turbines by Ian F Bennett](#)

Over a few years I attempted to add very primitive combustion chamber system to my turbo, in 1993 as my experience and initially primitive fabrication skills began to improve the design came together and a working stationary gas turbine engine emerged. More details of this pioneering unit can be found in chapter 8.

The Treager gas turbine title contained pictures of small stationary gas turbine engines called Auxiliary Power Units or APUs. An APU is a kind of “Donkey engine” which carries a utilitarian role onboard an aircraft. An APU is normally mounted onboard an aircraft and is used to drive electrical generators, hydraulic pumps, air compressors or the unit itself is used as an air compressor. APUs may operate when the aircraft is standing on the ground or when it is in the air. APUs are normally required to provide starting power for the aircraft propulsion engines if some sort of external power supply is not available. When on the ground the aircraft APU often runs for extended periods providing power for air conditioning, heat, light and of course all aircraft systems and avionics powered. In short, to keep the coffee hot and the beer cold!

The advantage of an APU onboard an aircraft is that it makes the plane self contained and able to operate without the use of ground support equipment. Most jet airliners fall into this category as do modern jet fighter aircraft. A notable exception to this was Concorde, this now decommissioned aircraft did not carry an APU and so was reliant on a ground based, normally trailer mounted gas turbine engine (sometimes a large piston engine driven compressor) to provide it with a starting air supply. Concorde carried only an emergency power unit (EPU) which was of course only used in an airborne emergency or power failure. Some large helicopters also carry a small gas turbine APU.



Garrett GTCP85 Auxiliary Power Unit

[Small Gas Turbines by Ian F Bennett](#)



An installed aircraft gas turbine auxiliary power unit

Small stationary gas turbine engines are not common (when compared to their piston counterparts) in other applications outside of aviation, they may sometimes be found driving ground-based generators and pumps. The Cold-War era of the 1950's and 1960's spawned a number of small stationary and portable units. The arms race and military budgets were such that during perhaps the hay day of small gas turbine development engines were produced for military and defense use. After the end of the Second World War many automotive manufacturers experimented with installing gas turbines in cars and trucks. The most famous example of this must be the car built in the US by Chrysler; the UK based Rover Car Company also built a series of prototypes. Since then other manufacturers such as Volvo and Toyota also produced gas turbine powered car prototypes.

[Small Gas Turbines by Ian F Bennett](#)



Rover BRM Gas Turbine Car



Chrysler Gas Turbine Car

[Small Gas Turbines by Ian F Bennett](#)

Gas turbines are sometimes used for standby power generation. Generator sets using purpose built or aero-derivative engine models can be found in the range 50KW-1MW. The Austin Motor company in the UK briefly produced a 250BHP stationary engine suitable for driving a 200KVa generator. In the USA Solar (International Harvester or Caterpillar) produced a 300BHP unit known as a GS350 or “Spartan” single shaft stationary engine.



250HP stationary gas turbine built by the Austin Motor Company



Solar Spartan GS350 300HP Gas Turbine

[Small Gas Turbines by Ian F Bennett](#)



A 30KW Micro-turbine generator unit (Capstone C30)

gasturbineworld.co.uk

[Small Gas Turbines by Ian F Bennett](#)

A company located in the USA today produce a remarkable small gas turbine known as the Capstone C30 micro-turbine. Capstone was founded by two ex-Garrett engineers two develop a small automotive gas turbine, in 1998 they began producing a stationary 30kw machine.

Micro-turbine is the name sometimes given to small scale power generation systems and light industrial combined heat and power (CHP or co-generation) installations. This modern state of the art engine consists of a small turbo-charger style (radial compressor and turbine) rotor running at very high speed and supported on special air bearings. The rotor directly drives a high-speed alternator electronic circuits that are used to “condition the power output” and convert it for conventional consumption. Conditioning the power output generally consists of rectifying and smoothing a high frequency electrical current and then passing it to solid state inverter equipment to turn it into a standard format power supply e.g. 240V 50Hz alternating current.

The C30 unit also incorporates a heat exchanger that is used to “re-cycle” the waste heat from its exhaust and pass it back into the combustion process. The fitment of a heat exchanger, sometimes referred to as a “recuperator” or “regenerator” reduces the fuel consumption of the engine and greatly improving efficiency. The C30 produces 30Kw and finds a number of stationary applications, particularly in the oil and gas industry, it may also be found in a number of prototype and experimental hybrid vehicles. Capstone now produce a series of larger units up to 200Kw in output. Other companies including Turbec, Elliott, Honeywell, Bowman Power Systems, Turbogenset and Ingersoll Rand also manufacture or have manufactured micro-turbine units. Throughout the past two decades microturbines have experienced mixed commercial success, a number of the above mentioned manufacturers have withdrawn their products from the market place. Turbogenset as a stand-alone company no longer exists.

A number of new microturbine companies have emerged. MTT in Holland have developed a medium scale CHP unit based on a small turbo-charger. A promising pre-production model appears to exist so scale production looks a possibility. Another company Bladon Jets look to be developing a 12Kw stationary unit. was originally claimed it would power a hybrid super-car as a range-extender, development now appears to focus on the stationary unit. Bladon are now manufacturing and marketing a 12Kw machine known as the MTG12. This unit is for use as a low-maintenance field generator for the telecoms industry.

[Small Gas Turbines by Ian F Bennett](#)

During the 1970's gas turbines appeared briefly in motor racing. Formula One and the American Indy car series both made use of gas turbine power plants in cars. Several teams including Lotus fitted helicopter type gas turbines to race cars, the Pratt and Whitney PT6 and the General Electric T58 models found applications here. The principal advantage of using a gas turbine in motor sport was to get around various regulations as there is no equivalent cubic capacity (CC) in a gas turbine. Specifying the air intake area was one way that regulations were eventually placed upon gas turbines which made them less competitive in terms of power output. There are significant problems with using gas turbines in motor sport including huge throttle lag, no engine braking and high fuel consumption.



Lotus 56 Formula One gas turbine car

[Small Gas Turbines by Ian F Bennett](#)



Le Howmet TX powered by a still-borne Continental TS325 (T65)

Continental TS325

Small Gas Turbines by Ian F Bennett

Today gas turbines are still used in motor sport; Drag Racing, Tractor Pulling and Powerboat racing find uses for ex-aircraft and helicopter units.



Gas turbine powered pulling tractor



Turbine power-boat (Miss Albatross RR GEM510)

[Small Gas Turbines by Ian F Bennett](#)

Around the world there are a few examples of where small gas turbine engines have been fitted to railway locomotives. In the UK a notable locomotive was built in the 1980s by British Rail engineering called the Advanced Passenger Train- experimental or APT-e. The APT was powered by four Leyland built (originally built for use in trucks) 350HP twin-shaft units fitted with rotating ceramic heat exchangers. The propulsion system was by the use of electric traction motors. A fifth turbine unit was used as an auxiliary power supply for the on board services. Another notable feature was special hydraulically controlled tilting bogies that allowed the train to navigate through sweeping bends at high speed. The train never made it in to production but the technology that was developed and the lessons learned contributed to later trains including the conventional diesel-electric High Speed Train or HST. (Intercity 125 Locomotive).



British Rail Advanced Passenger Train (APT)

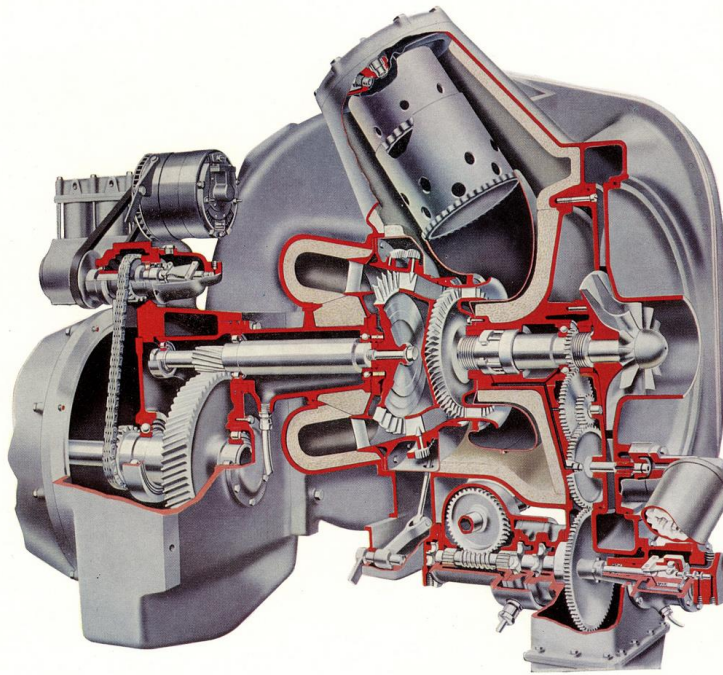

Leyland 350HP gas turbine

gasturbineworld.co.uk

[Small Gas Turbines by Ian F Bennett](#)

The Leyland 350HP gas turbine was designed as an experimental unit for use in trucks. A number of prototype vehicles were constructed. The Leyland unit followed other automotive gas turbine practice. It consisted of a twin shaft unit that was fitted with rotating glass ceramic heat exchangers. A slow turning glass/ceramic disc would rotate alternately through the exhaust gas stream and then the compressor discharge gas stream taking on and giving up heat as it went. As with the car development programs at the time, the heat exchangers proved to be difficult units to develop reliably and to produce an adequate service life.



Leyland prototype gas turbine powered truck

[Small Gas Turbines by Ian F Bennett](#)

In the 1960s a whole host of small engines were developed as starters and APUs for aircraft. These engines are magnificent works of mechanical art and very little has been written about them. One may consider these units to be collectable in the same way that many stationary reciprocating engines are collected and restored by enthusiasts. Most of these units may be operated as stationary engines with some basic knowledge of electronics and fluids.



Stationary engines: piston and gas turbine

This document is based around my experiences of over 30 years of acquiring and operating small gas turbine engines. In addition to developing the turbo charger based unit I have restored and instrumented many small aircraft type engines. I have met and corresponded with a number of other like-minded individuals which has provided further valuable experience and inspiration. On a number of occasions I have contributed to commercial, land speed record and aviation projects, from time to time I am asked for advice and information about small engines, this document seeks to condense my experience and provide technical information to assist others.

This document should never be used to substitute or override manufacturer's recommendations. It should be confined to ground based stationary gas turbine activities and not applied to any aircraft installations. The author cannot accept responsibility for any errors and the consequences of the information provided in this document. Gas turbine engines are potentially dangerous, always take safety precautions when operating such units.

[Small Gas Turbines by Ian F Bennett](#)

Looking around the world small gas turbine engines actually fulfill very few roles in modern prime-mover propulsion and power generation technologies. They are most common in aviation when used as APUs, starters and helicopter engines, outside this field the small gas turbine is complex, expensive and also bulky if the best fuel efficiency is to be realized. Even in aviation a power output barrier exists, below 300HP no commercially successful power plant exists. Small light private production aircraft (as opposed to experimental), and the smallest of helicopters are all equipped with cheaper piston engines such as the Lycoming flat-fours (O-360) and flat-sixes (O-540).

There is a steady growth in electric and hybrid vehicle technologies, a number of pure electric vehicles now exist and even ones with range extender generators but none so far employ a gas turbine as a prime mover.

Micro turbines

Micro turbines occupy a small niche in the power generation market, compared to reciprocating engines again they are found to be complex and expensive to manufacture. There are only a few micro-turbine manufacturers around the World and several others have come and gone in the past twenty years. A micro turbine requires the marriage of a number of key technologies including, low emissions combustor, simple economic gas turbine (turbo-machinery), recuperator (heat exchanger), high-speed alternator, sophisticated power conversion and control electronics. A micro turbine unit is often derived from components that are either built for or similar to turbo-charger components. It's a big challenge to build a reliable, efficient unit with economic life expectancy and running costs. For standby power and portable power generation reciprocating engines continue to improve providing fierce competition to the small gas turbine engine.

Micro turbines are often developed for operation on natural gas, some units may also be adapted to run on low BTU gaseous fuels such as land-fill gas derived from wastes disposal processes. Capstone produce liquid fueled variants that are able to run on diesel or kerosene. These units will have a different burner and fuel control system, converting a micro turbine from liquid to gas and visa versa may be a complex task requiring the replacement of many system components.

Capstone are the most successful and prolific supplier of micro turbine installations, they offer innovative air bearing oil-less technology and sophisticated computer control and monitoring. Three engine sizes are now offered from 30-200Kw and installations may incorporate exhaust heat recovery systems to further improve the overall fuel/thermal and economic efficiency. The Capstone micro turbine models offer the most potential for vehicle mounted hybrid installations or range extenders.

Other micro turbine manufacturers also exist, Ingersoll-Rand produced a 70Kw unit consisting of a natural gas fired conventional oil-lubricated turbo-charger style gas turbine unit operating as a gas generator, with recuperator, a free power turbine and geared low-speed alternator drive. The Ingersoll-Rand micro turbine business appears to have been sold and re-branded to Flex Energy. The company that now offers a larger 250Kw unit incorporating a single shaft gas turbine based

[Small Gas Turbines by Ian F Bennett](#)

on the industry model Kongsberg/Dresser-Rand KG2 with recuperator and geared low speed alternator.



Ingersoll-Rand 70Kw micro turbine unit

Small Gas Turbines by Ian F Bennett

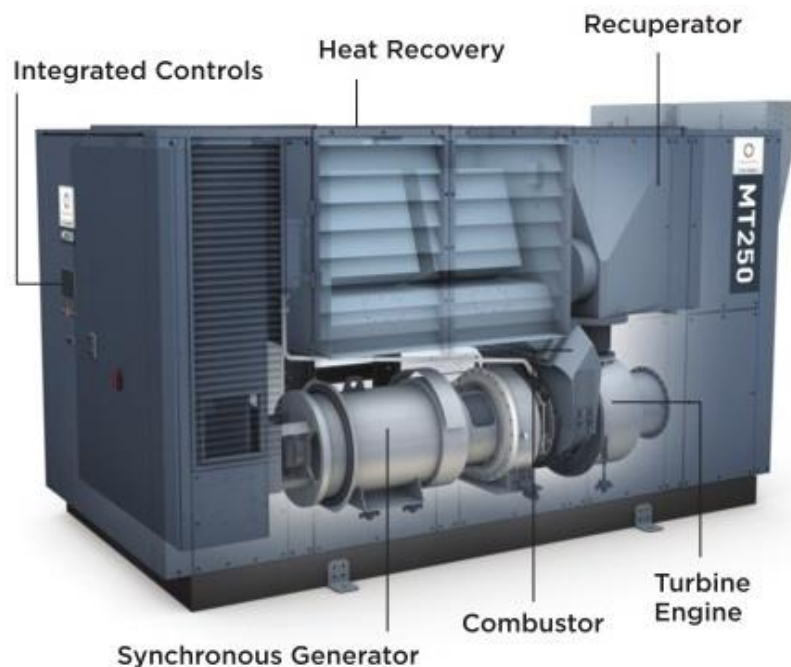

Flex Energy 250Kw micro turbine unit

The company Turbec offer a natural gas fired micro turbine unit originally derived from a automotive turbine developed by Volvo the T100. The conventionally oil-lubricated gas turbine is fitted with a high-speed directly driven alternator and external recuperator.

A company known as Elliott Energy Systems produced a 100Kw natural gas fired unit known as the TA-100. This unit featured a high speed alternator driven by a oil-lubricated and recuperated gas turbine engine. Elliott Energy Systems have now been sold to a company Caltenix a company offering magnetic bearings and other precision systems. Honeywell also developed a unit know as the Parallon 75, a 75Kw micro turbine that featured air bearings and a direct drive high speed alternator.

UK companies Bowman Power Systems and Turbo-Genset (TPS) produced small gas turbines of the micro turbine type during the 1990s, today both these companies continue to offer electronics or turbo-machinery products but not complete gas turbine power plants.



Turbec 100Kw micro turbine also fitted with exhaust heat recovery system

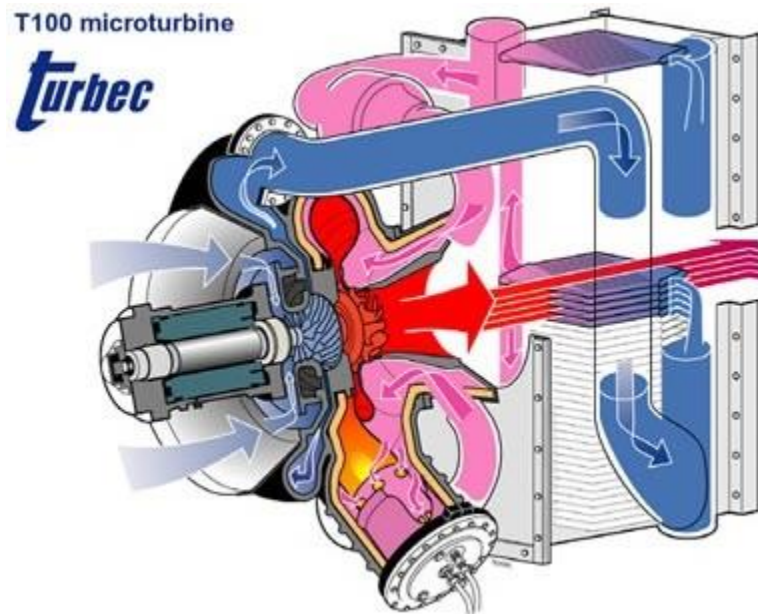

T100 100Kw gas turbine with recuperator

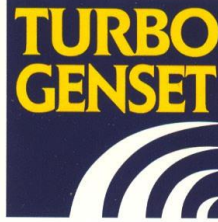

TG-40 PORTABLE TURBO GENSET

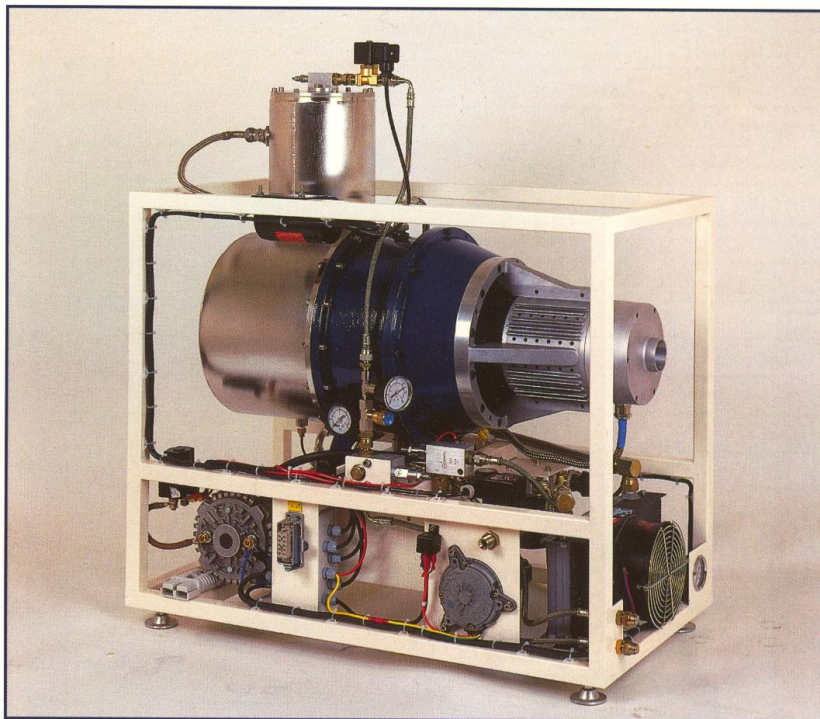

“Hand portable genset powered by a small gas turbine”

- Multi-fuel capability
- 37kW electrical power
- AC or DC output options
- Easy installation
- Hand portable
- Gas turbine reliability
- Minimum maintenance
- No reduction gearbox

The TG-40 genset combines a small gas turbine with a directly driven high speed generator. Direct drive eliminates the need for the large and costly reduction gearbox. The size and weight of the TG-40 are only a fraction of those of comparable diesel gensets.

The TG-40 is ideally suited for a wide range of stationary and mobile applications where portability, reliability, ease of maintenance and ease of installation are important.

TG50

**TURBO
GENSET**

TG50 MOBILE TURBO GENSET

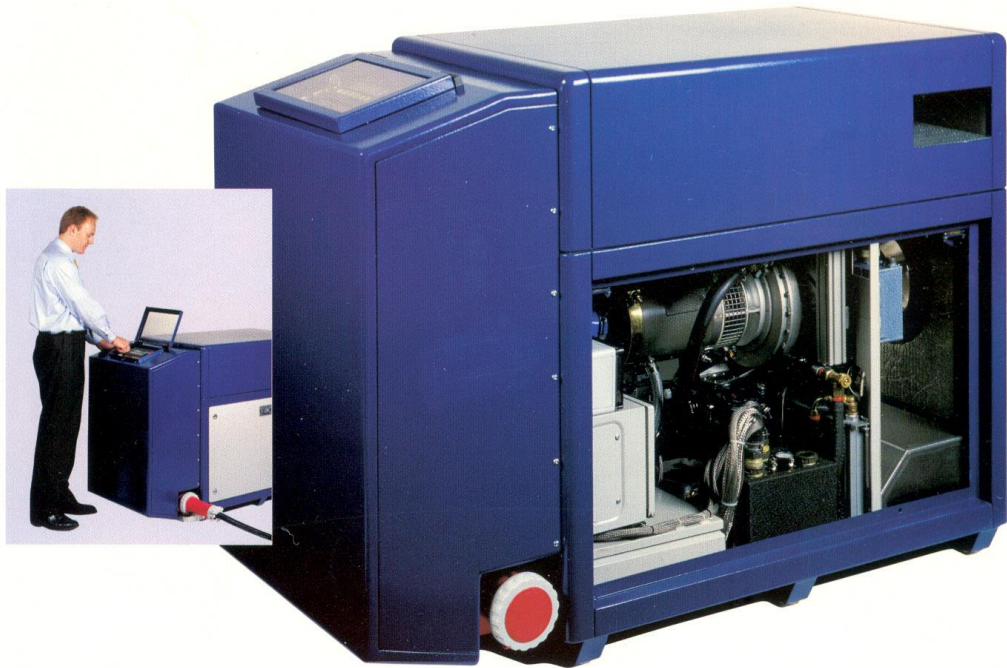

*“Technological breakthrough in high speed
electrical power generation”*

50kVA ELECTRICAL OUTPUT POWER AT 52,400 RPM

- Gas turbine prime mover
- Direct drive high speed generator
- Compact, light and reliable
- Low noxious emissions
- Low installation cost and maintenance
- Multi-fuel capability
- High-grade exhaust heat suitable for CHP

[Small Gas Turbines by Ian F Bennett](#)

A US company known as Twin Micro Turbine Alternator power (TMA power LLC) claim to have built a micro turbine unit producing 70Kw. This unusual unit incorporates a two stage compressor system with two spools and it drives the alternator from one spool.



Twin spool micro turbine unit with high speed alternator

Other turbines from around the World

The Japanese turbocharger manufacturer IHI (Ishikawajima-Harima Heavy Industries) produced a truly remarkable small gas turbine generator set known as the Dynajet. No other manufacturer anywhere in the world has put such a device in to production, and the unit is no longer made. It's not clear how many were actually produced but evidence of the genuine existence of such a product was found on an auction surplus website, and the author was eventually able to purchase one. IHI offered a very small portable generator set consisting of a tiny gas turbine with recuperator and high speed alternator. Power output was just 2.6Kw and the unit is designed to run on kerosene type fuel. The package would also have included sophisticated electronics to manage and automate the turbine operation.



IHI manufactured portable gas turbine generator set

The Dynajet uses a conventional oil lubricated gas turbine running up to 100,000 rpm. A single can type burner runs on kerosene. The engine is started using an on-board 24V ni-cad battery and ignition is effected with a glow plug. Intake and exhaust silencers and a built in fuel tank make up a neat package. A typically well-engineered Japanese product with high quality automotive derived parts.

[Small Gas Turbines by Ian F Bennett](#)

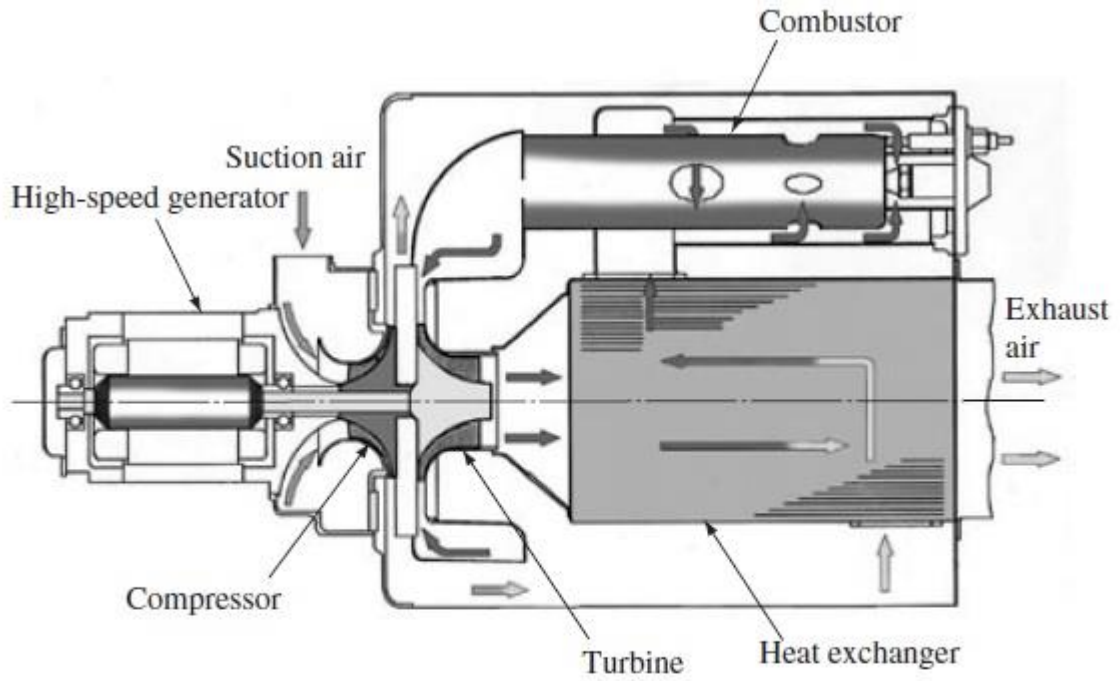

Schematic diagram of engine

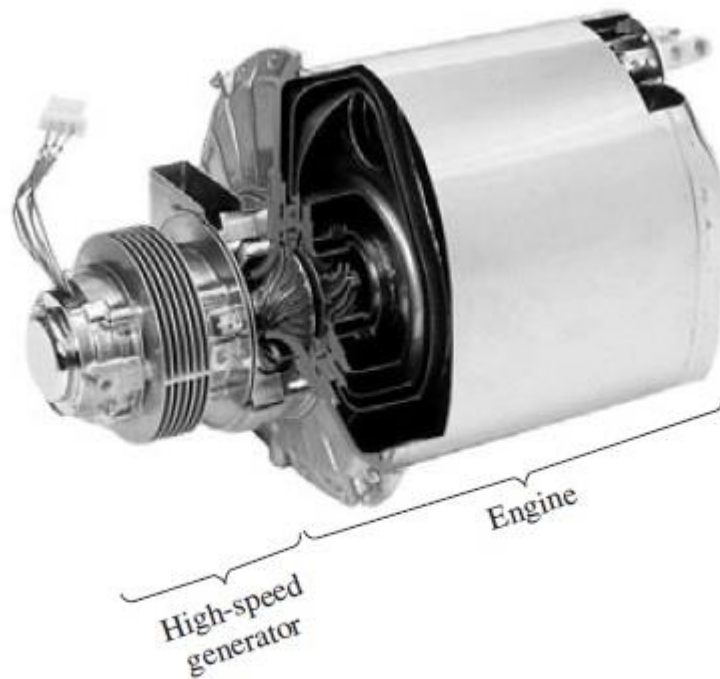

High-speed generator and engine

MTT (Micro Turbine Technology) EnerTwin

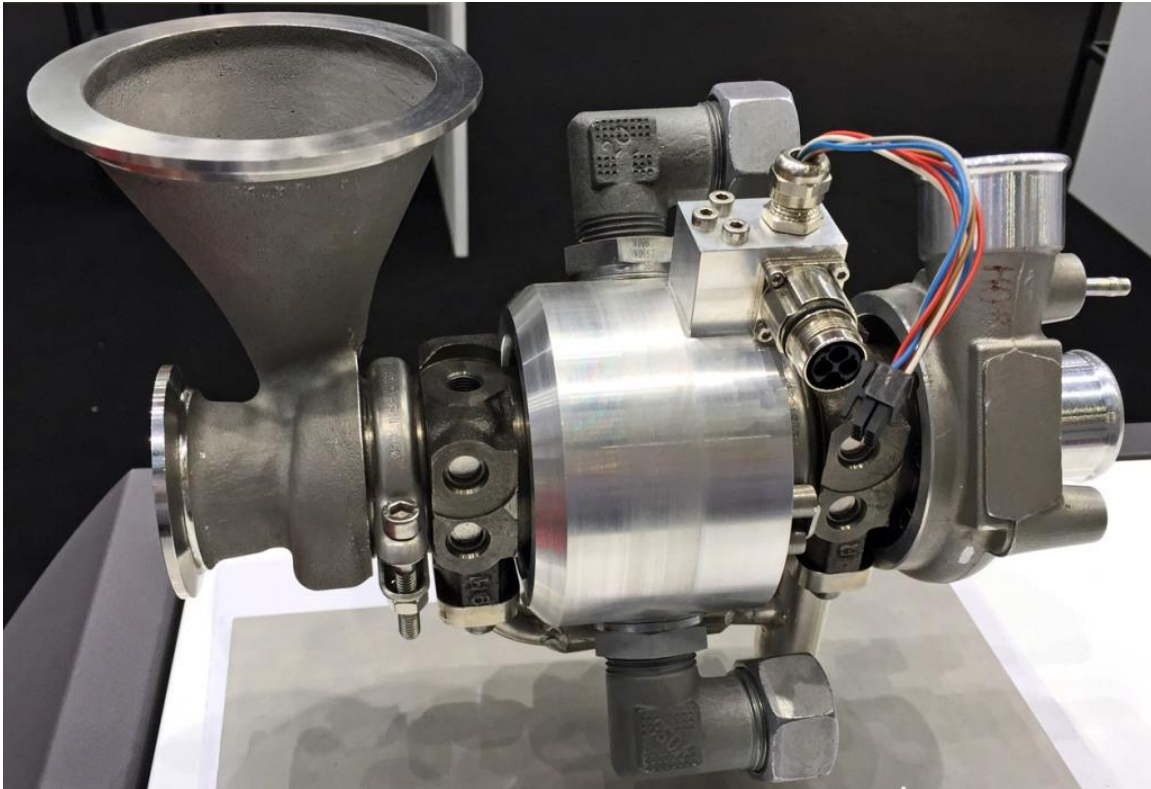

MTT Microturbine (combustor removed)

A Dutch company Micro Turbine Technology have built a medium scale combined heat and power unit based on a 3Kw gas turbine. Development appears to have reached consumer trials stage for the CHP unit. Other applications have been suggested such as an APU unit for large trucks and a range extender for electric cars. Simple conventional turbocharger mechanicals are utilized with a small alternator placed between the turbine and the compressor. A less radical but none the less innovative unit compared to others that is making genuine progress towards real production.

[Small Gas Turbines by Ian F Bennett](#)

R H Philips and Son Turbocharger derived gas turbine engine. In the 1970s Belfast university embarked on a project to produce a low-cost turbo-jet engine for UAV and drone use. They developed a small unit from a turbo-charger core. The unit was subsequently developed into a compressor unit (air-bleed off) and smoke generator unit. If special low toxicity oil is injected into a hot gas turbine exhaust a large dense fog or smoke is produced. This fog may be used for theatrical screening, special effects on movie sets and for tactical screening in battlefield settings. An unusual and uncommon design of small engine. The turbo-charger featured the normal hydrodynamic plain type bearing and radial flow rotors. An advantage of turbo-charger based designs is robustness and containment. The small turbine rotor is contained inside a heavy thick-cast nozzle volute that can contain a failure.

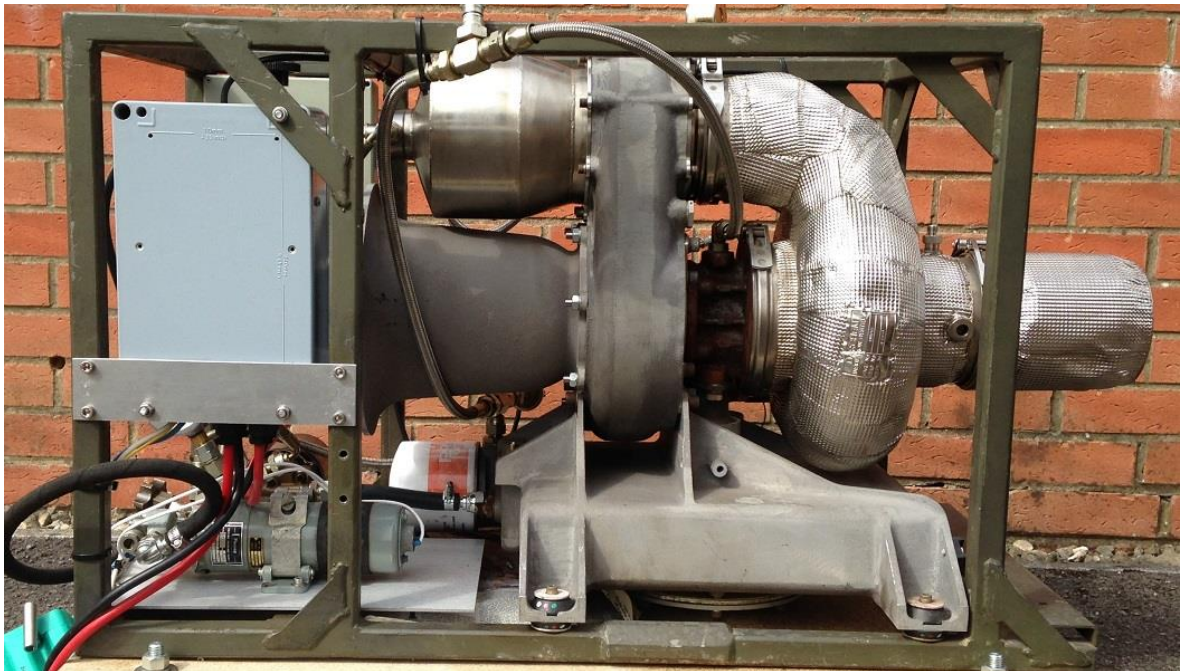

Turbo-charger derived gas turbine compressor unit

[Small Gas Turbines by Ian F Bennett](#)

Jakadofsky

An Austrian company Jakadofsky produce a range of small turbo-shaft engines that are derived from a RC model aircraft mechanical layout. Jakadofsky are the only company to have successfully adapted a RC model type engine for continuous power generation. The company offers a “Jet Volt Turbo-Generator APU/GPU” unit consisting of a single spool engine driving an alternator at intermediate speed via a special reduction gear. The unit is rated at 300A at 28V and consumes 2.5 gallons per hour.



JetVolt AC & DC generator sets for aircraft and general power use

PBS

První brněnská strojírna Velká Bíteš, a.s. (PBS) a company from the Czech Republic produce a range of aerospace turbo-machinery including APUs, a turbojet and a turboprop engine. The PBS gas turbine products are developments of the Microturbo Saphir range of APUs. PBS manufacture a number of these units under license, they have also developed a small turbojet, turboshaft and turbo-prop engines from them.

A remarkable unit known as the TP100 consists of a Microturbo Saphir derived gas generator unit coupled to a free turbine unit and gearbox assembly. If safety, reliability, life, certification and fuel consumption requirements can be met this unit could occupy a sector in the general aviation power plant market not previously belonging to a gas turbine. Power output is claimed at 180Kw and with the installed propeller some 5000N (2200LBs) thrust.



PBS TP100 turbo-prop engine (pusher)

[Small Gas Turbines by Ian F Bennett](#)

From the experience of small gas turbine applications, the types of engines that may be found fall neatly into three basic categories-

1. Home or experimentally constructed stationary gas turbines based around a complete automotive turbo-charger. An engine is formed simply by adding a combustion chamber between the compressor outlet and turbine inlet of the turbocharger. Accessories and services are provided by external equipment usually electrically powered.



A homebuilt gas turbine engine utilizing an automotive turbocharger

2. Home or commercially constructed miniature turbo-jet engines intended for the propulsion of model aircraft. These units may be constructed from the rotating core of turbo chargers or may be completely fabricated from scratch. A number of manufacturers now offer ready to run gas turbine engines, prices start at about £1000.



RC model aircraft gas type turbine engine

[Small Gas Turbines by Ian F Bennett](#)

3. Commercially built gas turbines intended for small drone-type aircraft propulsion, aircraft starting or auxiliary services and light helicopters, these engines are obtained as obsolete, surplus, scrap or life expired units. This document seeks to concentrate on these units and how they operate.

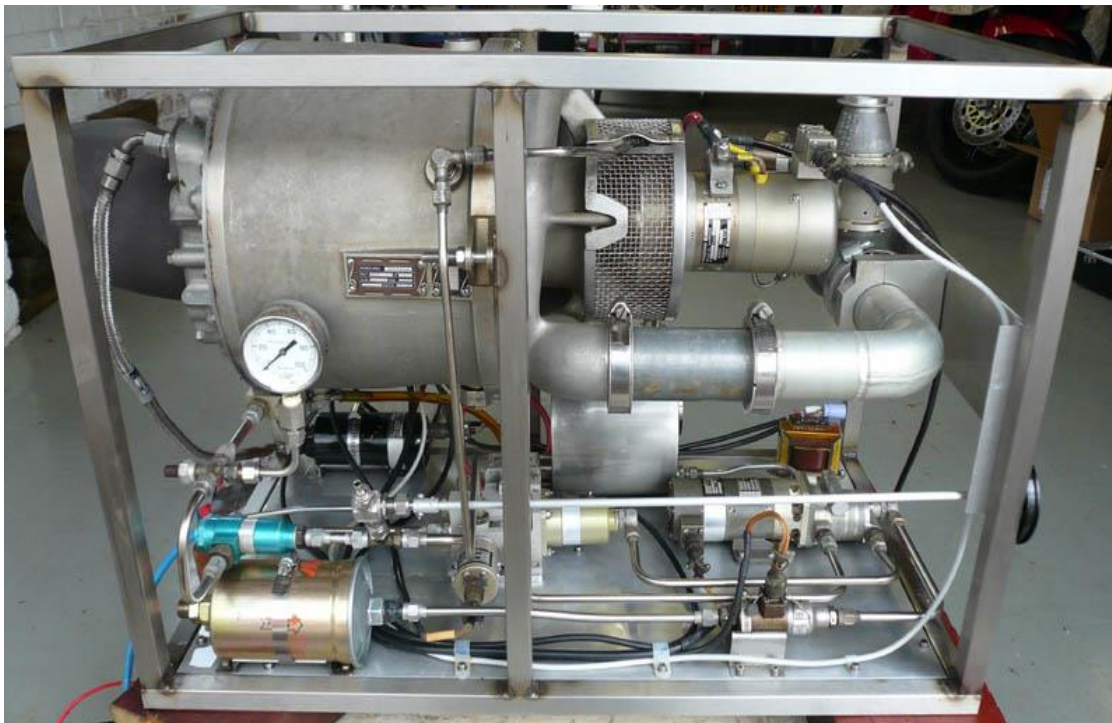

Commercially built gas turbine engine auxiliary power unit (APU)

I will apply here the definition of "small" to a gas turbine of up to 1000 horsepower. Most APUs and gas turbines intended as aircraft engine starters fall into this category. Much of the techniques and technology of small units may also be found in medium-size and larger gas turbine engines such as helicopter engines, turbo-propeller engines, turbojets and turbo fans. Small turbo-jet engines intended for un-manned missile and UAV (Unmanned Aerial Vehicle) propulsion are similar in design to APUs. This document will concentrate on this engine category but in chapter 8 it will detail how a turbo charger based stationary engine can be built.



Small Turbo-Jet engine for fitment to UAV target drone. (Microturbo TJA24)